

FEATURES

- True Color PWM™ Delivers Constant Color with 400:1 Dimming Range
- Wide Input Range: 4V to 36V
- Up to 1A LED Current
- Adjustable 200kHz–2MHz Switching Frequency
- Adjustable Control of LED Current
- Integrated Boost Diode
- High Output Current Accuracy is Maintained Over a Wide Range from 35mA to 1A
- Open LED (LT3474) and Short-Circuit Protection
- High Side Sense Allows Grounded Cathode Connection
- Uses Small Inductors and Ceramic Capacitors
- LT3474-1 Drives LED Strings Up to 26V
- Compact 16-Lead TSSOP Thermally Enhanced Surface Mount Package

APPLICATIONS

- Automotive and Avionic Lighting
- Architectural Detail Lighting
- Display Backlighting
- Constant Current Sources

LT, LT, LTC and LTM are registered trademarks of Linear Technology Corporation. True Color PWM is a trademark of Linear Technology Corporation. All other trademarks are the property of their respective owners. Patent Pending

DESCRIPTION

The LT[®]3474/LT3474-1 are fixed frequency step-down DC/DC converters designed to operate as constant-current sources. An internal sense resistor monitors the output current allowing accurate current regulation, ideal for driving high current LEDs. High output current accuracy is maintained over a wide current range, from 35mA to 1A, allowing a wide dimming range.

Unique PWM circuitry allows a dimming range of 400:1, avoiding the color shift normally associated with LED current dimming.

The high switching frequency offers several advantages, permitting the use of small inductors and ceramic capacitors. Small inductors combined with the 16-lead TSSOP surface mount package save space and cost versus alternative solutions. The constant switching frequency combined with low-impedance ceramic capacitors result in low, predictable output ripple.

With their wide input range of 4V to 36V, the LT3474/LT3474-1 regulate a broad array of power sources, from 5V logic rails to unregulated wall transformers, lead acid batteries and distributed power supplies. A current mode PWM architecture provides fast transient response and cycle-by-cycle current limiting. Frequency foldback and thermal shutdown provide additional protection.

TYPICAL APPLICATION

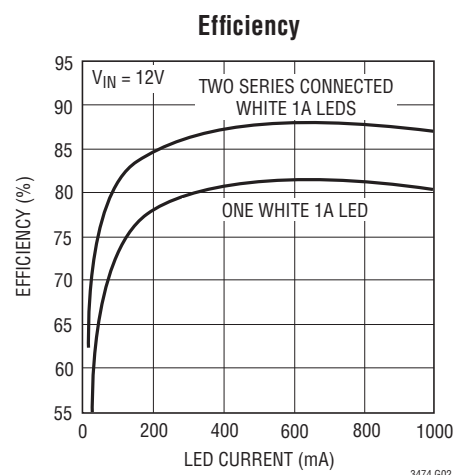
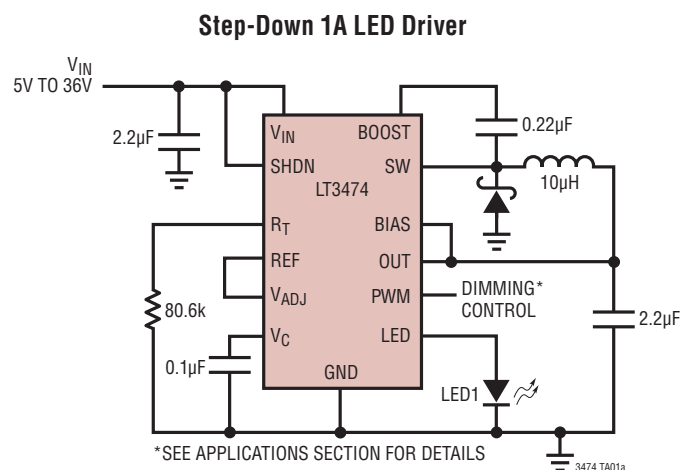

LT3474/LT3474-1

ABSOLUTE MAXIMUM RATINGS

(Note 1)

V_{IN} Pin	(-0.3V), 36V
BIAS Pin.....	25V
BOOST Pin Voltage	51V
BOOST above SW Pin	25V
OUT, LED Pins (LT3474)	15V
OUT, LED Pins (LT3474-1).....	26V
PWM Pin.....	10V
V_{ADJ} Pin	6V
V_C , REF, R_T Pins	3V
SHDN Pin.....	V_{IN}
BIAS Pin Current.....	1A
Maximum Junction Temperature (Note 2).....	125°C
Operating Temperature Range (Note 3)	
LT3474E, LT3474E-1	-40°C to 85°C
LT3474I, LT3474I-1	-40°C to 125°C
Storage Temperature Range.....	-65°C to 150°C
Lead Temperature (Soldering, 10 sec)	300°C

PIN CONFIGURATION

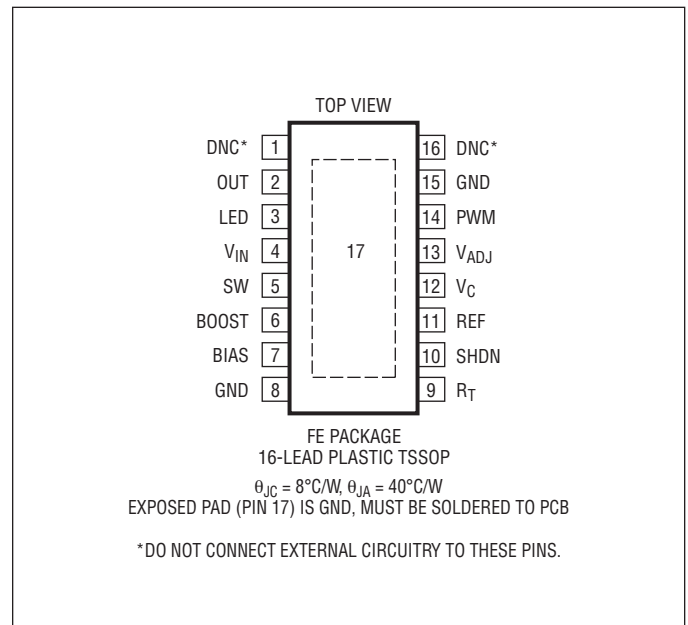

ORDER INFORMATION

LEAD FREE FINISH	TAPE AND REEL	PART MARKING	PACKAGE DESCRIPTION	TEMPERATURE RANGE
LT3474EFE#PBF	LT3474EFE#TRPBF	3474EFE	16-Lead TSSOP	-40°C to 85°C
LT3474IFE#PBF	LT3474IFE#TRPBF	3474IFE	16-Lead TSSOP	-40°C to 125°C
LT3474EFE-1#PBF	LT3474EFE-1#TRPBF	3474EFE-1	16-Lead TSSOP	-40°C to 85°C
LT3474IFE-1#PBF	LT3474IFE-1#TRPBF	3474IFE-1	16-Lead TSSOP	-40°C to 125°C

Consult LTC Marketing for parts specified with wider operating temperature ranges.

Consult LTC Marketing for information on non-standard lead based finish parts.

For more information on lead free part marking, go to: <http://www.linear.com/leadfree/>

For more information on tape and reel specifications, go to: <http://www.linear.com/tapeandreeel/>

ELECTRICAL CHARACTERISTICS The ● denotes the specifications which apply over the full operating temperature range, otherwise specifications are at $T_A = 25^\circ\text{C}$. $V_{IN} = 12\text{V}$, $V_{BOOST} = 16\text{V}$, $V_{OUT} = 4\text{V}$ unless otherwise noted (Note 3).

PARAMETER	CONDITIONS	MIN	TYP	MAX	UNITS	
Minimum Input Voltage		●	3.5	4	V	
Input Quiescent Current	Not Switching		2.6	4	mA	
Shutdown Current	SHDN = 0.3V, $V_{BOOST} = 0\text{V}$, $V_{OUT} = 0\text{V}$		0.01	2	μA	
LED Pin Current	V_{ADJ} Tied to V_{REF}	●	0.98	1	1.02	A
		●	0.968		1.025	A
	V_{ADJ} Tied to $V_{REF}/5$	●	0.193	0.2	0.207	A
		●	0.186		0.210	A
REF Voltage		●	1.23	1.25	1.265	V

3474fd

ELECTRICAL CHARACTERISTICS The ● denotes the specifications which apply over the full operating temperature range, otherwise specifications are at $T_A = 25^\circ\text{C}$. $V_{IN} = 12\text{V}$, $V_{BOOST} = 16\text{V}$, $V_{OUT} = 4\text{V}$ unless otherwise noted (Note 3).

PARAMETER	CONDITIONS		MIN	TYP	MAX	UNITS
Reference Voltage Line Regulation	$5\text{V} < V_{IN} < 36\text{V}$			0.01		%/V
Reference Voltage Load Regulation	$0 < I_{REF} < 250\mu\text{A}$			0.0002		%/ μA
V_{ADJ} Pin Bias Current (Note 4)		●		20	400	nA
Switching Frequency	$R_T = 80.6\text{k}$	●	470 450	500	530 540	kHz kHz
Maximum Duty Cycle	$R_T = 80.6\text{k}$ $R_T = 10\text{k}$ $R_T = 232\text{k}$	●	90	95 76 98		% % %
Foldback Frequency	$R_T = 80.6\text{k}$, $V_{OUT} = 0\text{V}$			70		kHz
SHDN Threshold (to Switch)			2.6	2.65	2.7	V
SHDN Pin Current (Note 5)	$V_{SHDN} = \text{SHDN Threshold}$		8.3	10.3	12.3	μA
PWM Threshold			0.4	0.9	1.2	V
V_C Switching Threshold				0.8		V
V_C Source Current	$V_C = 1\text{V}$			100		μA
V_C Sink Current	$V_C = 1\text{V}$			100		μA
LED to V_C Current Gain				1.5		$\mu\text{A}/\text{mA}$
LED to V_C Transresistance				1		V/ mA
V_C to Switch Current Gain				2		A/V
V_C Clamp Voltage				1.9		V
V_C Pin Current in PWM Mode	$V_C = 1\text{V}$, $V_{PWM} = 0.3\text{V}$	●		0.01	1	μA
OUT Pin Clamp Voltage (LT3474)			13.2	13.8	14.5	V
OUT Pin Current in PWM Mode	$V_{OUT} = 4\text{V}$, $V_{PWM} = 0.3\text{V}$	●		0.1	10	μA
Switch Current Limit (Note 6)	-40°C to 85°C LT3474I, LT3474I-1 at 125°C	●	1.6 1.5	2.1	3.2 3.2	A A
Switch V_{CESAT}	$I_{SW} = 1\text{A}$			380	500	mV
Boost Pin Current	$I_{SW} = 1\text{A}$			30	50	mA
Switch Leakage Current				0.01	1	μA
Minimum Boost Voltage (Note 7)				1.9	2.5	V
Boost Diode Forward Voltage	$I_{DIO} = 100\text{mA}$			600		mV

Note 1: Stresses beyond those listed under Absolute Maximum Ratings may cause permanent damage to the device. Exposure to any Absolute Maximum Rating condition for extended periods may affect device reliability and lifetime.

Note 2: This IC includes overtemperature protection that is intended to protect the device during momentary overload conditions. Junction temperature will exceed 125°C when overtemperature protection is active. Continuous operation above the specified maximum operating junction temperature may impair device reliability.

Note 3: The LT3474E and LT3474E-1 are guaranteed to meet performance specifications from 0°C to 70°C . Specifications over the -40°C to 85°C

operating temperature range are assured by design, characterization and correlation with statistical process controls. The LT3474I and LT3474I-1 are guaranteed to meet performance specifications over the -40°C to 125°C operating temperature range.

Note 4: Current flows out of pin.

Note 5: Current flows into pin.

Note 6: Current limit is guaranteed by design and/or correlation to static test. Slope compensation reduces current limit at higher duty cycles.

Note 7: This is the minimum voltage across the boost capacitor needed to guarantee full saturation of the internal power switch.

TYPICAL PERFORMANCE CHARACTERISTICS

LED Current vs V_{ADJ}

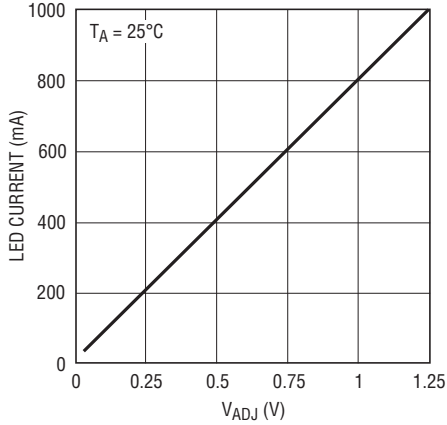

3474 G03

LED Current vs Temperature

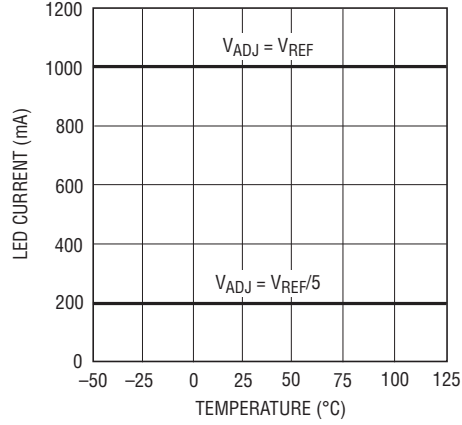

3474 G04

Switch Voltage Drop

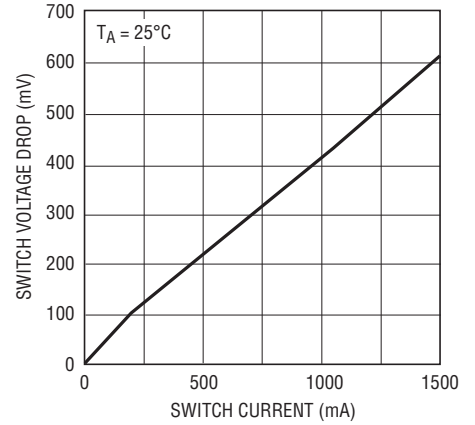

3474 G05

Current Limit vs Duty Cycle

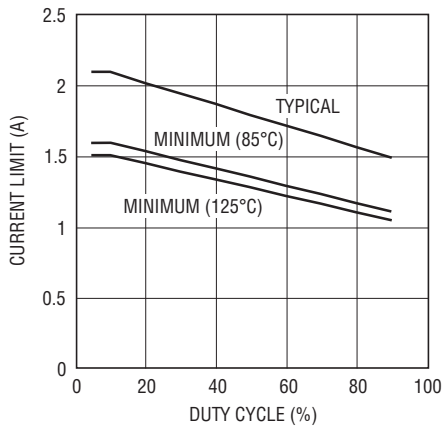

3474 G06

Switch Current Limit vs Temperature

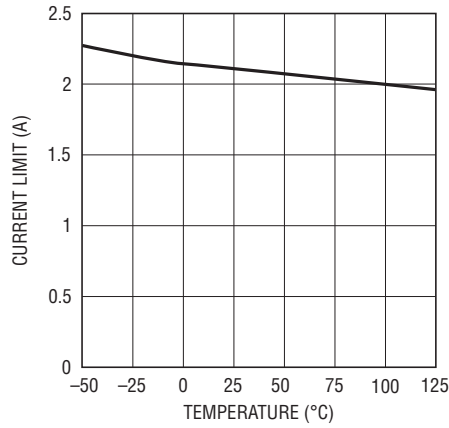

3474 G07

Current Limit vs Output Voltage

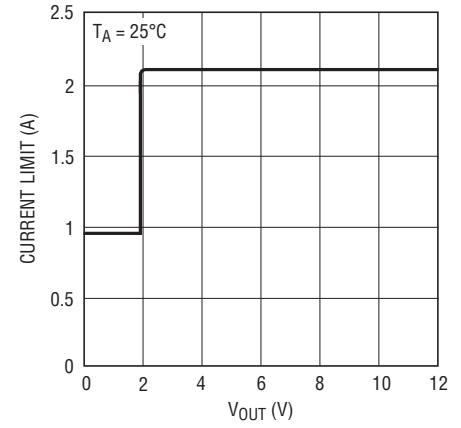

3474 G08

Oscillator Frequency vs R_T

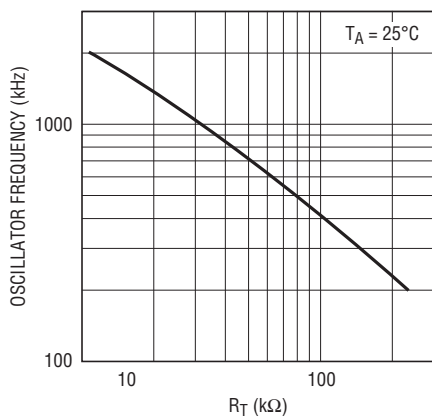

3474 G09

Oscillator Frequency vs Temperature

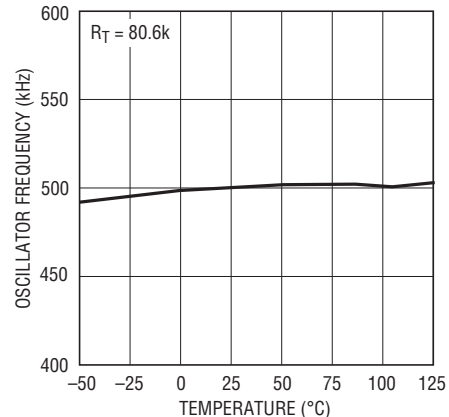

3474 G10

Oscillator Frequency Foldback

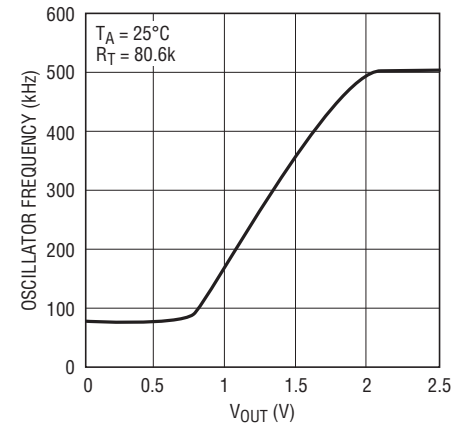

3474 G11

TYPICAL PERFORMANCE CHARACTERISTICS

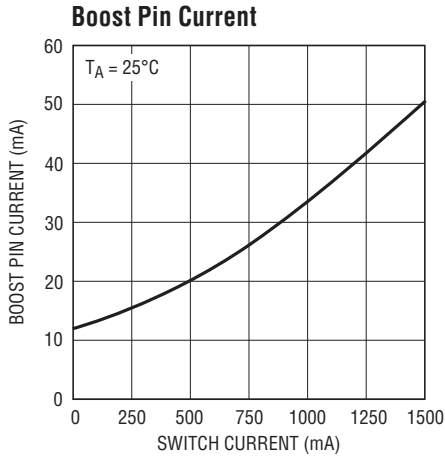

3473 G12

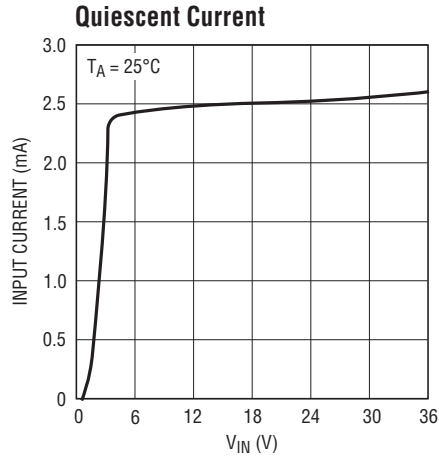

3474 G13

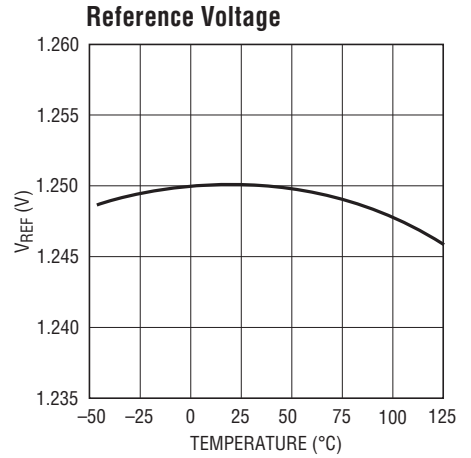

3474 G14

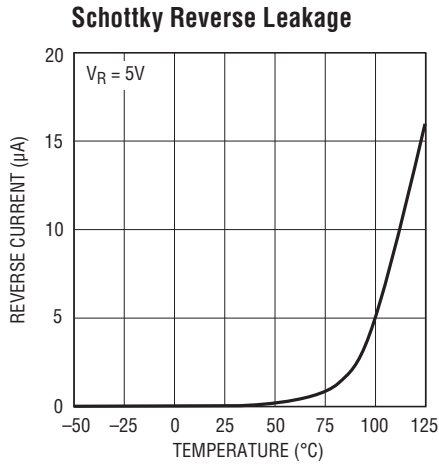

3474 G15

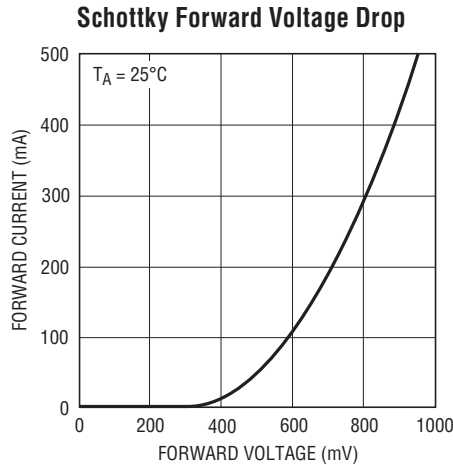

3474 G19

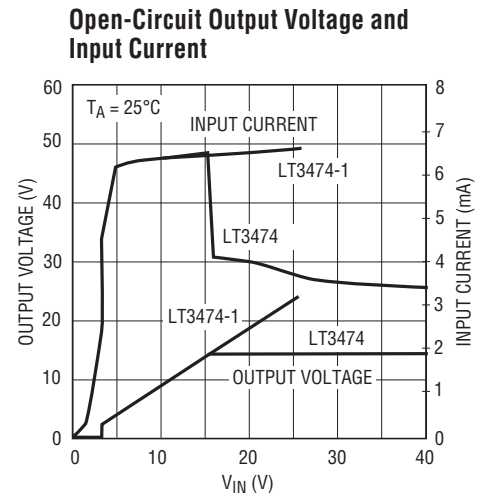

3474 G16

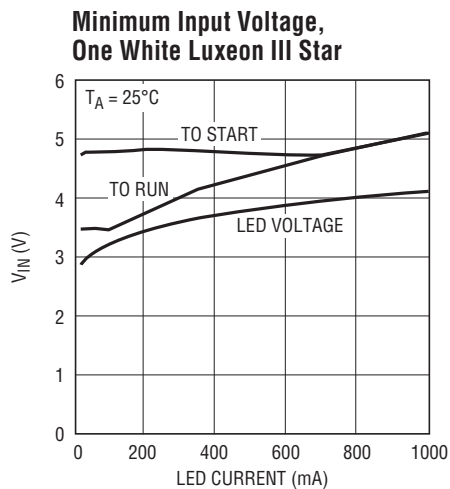

3474 G17

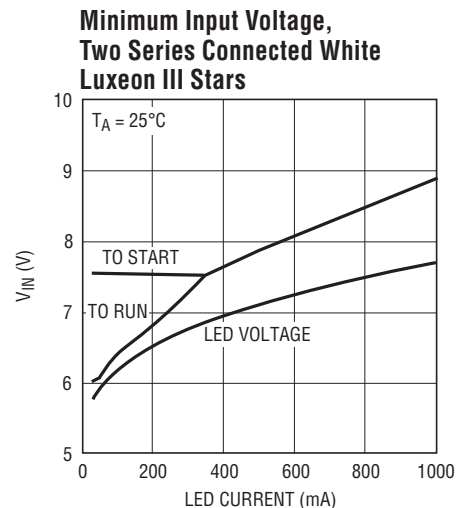

3474 G18

PIN FUNCTIONS

DNC (Pins 1, 16): Do not connect external circuitry to these pins, or tie them to GND. Leave the DNC pins floating.

OUT (Pin 2): The OUT pin is the input to the current sense resistor. Connect this pin to the inductor and the output capacitor.

LED (Pin 3): The LED pin is the output of the current sense resistor. Connect the anode of the LED here.

V_{IN} (Pin 4): The V_{IN} pin supplies current to the internal circuitry and to the internal power switch and must be locally bypassed.

SW (Pin 5): The SW pin is the output of the internal power switch. Connect this pin to the inductor and switching diode.

BOOST (Pin 6): The BOOST pin is used to provide a drive voltage, higher than the input voltage, to the internal bipolar NPN power switch.

BIAS (Pin 7): The BIAS pin connects through a Schottky diode to BOOST. Tie to OUT.

GND (Pins 8, 15, Exposed Pad Pin 17): Ground. Tie both GND pins and the Exposed Pad directly to the ground plane. The Exposed Pad metal of the package provides both electrical contact to ground and good thermal contact to the printed circuit board. It must be soldered to the circuit board for proper operation.

R_T (Pin 9): The R_T pin is used to set the internal oscillator frequency. Tie an 80.6k resistor from R_T to GND for a 500kHz switching frequency.

SHDN (Pin 10): The SHDN pin is used to shut down the switching regulator and the internal bias circuits. The 2.6V switching threshold can function as an accurate under-voltage lockout. Pull below 0.3V to shut down the LT3474/LT3474-1. Pull above 2.65V to enable the LT3474/LT3474-1. Tie to V_{IN} if the SHDN function is unused.

REF (Pin 11): The REF pin is the buffered output of the internal reference. Either tie the REF pin to the V_{ADJ} pin for a 1A output current, or use a resistor divider to generate a lower voltage at the V_{ADJ} pin. Leave this pin unconnected if unused.

V_C (Pin 12): The V_C pin is the output of the internal error amp. The voltage on this pin controls the peak switch current. Use this pin to compensate the control loop.

V_{ADJ} (Pin 13): The V_{ADJ} pin is the input to the internal voltage to current amplifier. Connect the V_{ADJ} pin to the REF pin for a 1A output current. For lower output currents, program the V_{ADJ} pin using the following formula:

$$I_{LED} = 1A \cdot V_{ADJ}/1.25V.$$

PWM (Pin 14): The PWM pin controls the connection of the V_C pin to the internal circuitry. When the PWM pin is low, the V_C pin is disconnected from the internal circuitry and draws minimal current. If the PWM feature is unused, leave this pin unconnected.

APPLICATIONS INFORMATION

Operation

The LT3474 is a constant frequency, current mode regulator with an internal power switch capable of generating a constant 1A output. Operation can be best understood by referring to the Block Diagram.

If the SHDN pin is tied to ground, the LT3474 is shut down and draws minimal current from the input source tied to V_{IN} . If the SHDN pin exceeds 1.5V, the internal bias circuits turn on, including the internal regulator, reference, and oscillator. The switching regulator will only begin to operate when the SHDN pin exceeds 2.65V.

The switcher is a current mode regulator. Instead of directly modulating the duty cycle of the power switch, the feedback loop controls the peak current in the switch during each cycle. Compared to voltage mode control, current mode control improves loop dynamics and provides cycle-by-cycle current limit.

A pulse from the oscillator sets the RS flip-flop and turns on the internal NPN bipolar power switch. Current in the switch and the external inductor begins to increase. When this current exceeds a level determined by the voltage at V_C , current comparator C1 resets the flip-flop, turning off the switch. The current in the inductor flows through the external Schottky diode and begins to decrease. The cycle begins again at the next pulse from the oscillator. In this way, the voltage on the V_C pin controls the current through the inductor to the output. The internal error amplifier regulates the output current by continually adjusting the V_C pin voltage. The threshold for switching on the V_C pin is 0.8V, and an active clamp of 1.9V limits the output current.

The voltage on the V_{ADJ} pin sets the current through the LED pin. The NPN Q2 pulls a current proportional to the voltage on the V_{ADJ} pin through the 100 Ω resistor. The g_m amplifier servos the V_C pin to set the current through the 0.1 Ω resistor and the LED pin. When the voltage drop

across the 0.1 Ω resistor is equal to the voltage drop across the 100 Ω resistor, the servo loop is balanced.

Tying the REF pin to the V_{ADJ} pin sets the LED pin current to 1A. Tying a resistor divider to the REF pin allows the programming of LED pin currents of less than 1A. LED pin current can also be programmed by tying the V_{ADJ} pin directly to a voltage source up to 1.25V.

An LED can be dimmed with pulse width modulation using the PWM pin and an external NFET. If the PWM pin is unconnected or pulled high, the part operates nominally. If the PWM pin is pulled low, the V_C pin is disconnected from the internal circuitry and draws minimal current from the compensation capacitor. Circuitry drawing current from the OUT pin is also disabled. This way, the V_C pin and the output capacitor store the state of the LED pin current until PWM is pulled high again. This leads to a highly linear relationship between pulse width and output light, allowing for a large and accurate dimming range.

The R_T pin allows programming of the switching frequency. For applications requiring the smallest external components possible, a fast switching frequency can be used. If very low or very high input voltages are required, a slower switching frequency can be programmed.

During startup V_{OUT} will be at a low voltage. The NPN Q2 can only operate correctly with sufficient voltage at V_{OUT} , around 1.7V. A comparator senses V_{OUT} and forces the V_C pin high until V_{OUT} rises above 2V, and Q2 is operating correctly.

The switching regulator performs frequency foldback during overload conditions. An amplifier senses when V_{OUT} is less than 2V and begins decreasing the oscillator frequency down from full frequency to 20% of the nominal frequency when $V_{OUT} = 0V$. The OUT pin is less than 2V during startup, short circuit, and overload conditions. Frequency foldback helps limit switch current under these conditions.

APPLICATIONS INFORMATION

The switch driver operates either from V_{IN} or from the BOOST pin. An external capacitor and internal Schottky diode are used to generate a voltage at the BOOST pin that is higher than the input supply. This allows the driver to saturate the internal bipolar NPN power switch for efficient operation.

Open Circuit Protection

The LT3474 has internal open circuit protection. If the LED is absent or fails open, the LT3474 clamps the voltage on the LED pin at 14V. The switching regulator then skips cycles to limit the input current. The LT3474-1 has no internal open circuit protection. With the LT3474-1, be careful not to violate the ABSMAX voltage of the BOOST pin; if $V_{IN} > 25V$, external open circuit protection circuitry (as shown in Figure 2) may be necessary. The output voltage during an open LED condition is shown in the Typical Performance Characteristics section.

Undervoltage Lockout

Undervoltage lockout (UVLO) is typically used in situations where the input supply is current limited, or has high source resistance. A switching regulator draws constant power from the source, so the source current increases as the source voltage drops. This looks like a negative resistance load to the source and can cause the source to current limit or latch low under low source voltage conditions. UVLO prevents the regulator from operating at source voltages where these problems might occur.

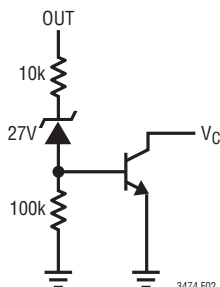

Figure 2. External Overvoltage Protection Circuitry for the LT3474-1.

An internal comparator will force the part into shutdown when V_{IN} falls below 3.5V. If an adjustable UVLO threshold is required, the SHDN pin can be used. The threshold voltage of the SHDN pin comparator is 2.65V. A internal resistor pulls $10.3\mu A$ to ground from the SHDN pin at the UVLO threshold.

Choose resistors according to the following formula:

$$R2 = \frac{2.65V}{\frac{V_{TH} - 2.65V}{R1} - 10.3\mu A}$$

V_{TH} = UVLO Threshold

Example: Switching should not start until the input is above 8V.

$$V_{TH} = 8V$$

$$R1 = 100k$$

$$R2 = \frac{2.65V}{\frac{8V - 2.65V}{100k} - 10.3\mu A} = 61.9k$$

Keep the connections from the resistors to the SHDN pin short and make sure the coupling to the SW and BOOST pins is minimized. If high resistance values are used, the SHDN pin should be bypassed with a 1nF capacitor to prevent coupling problems from switching nodes.

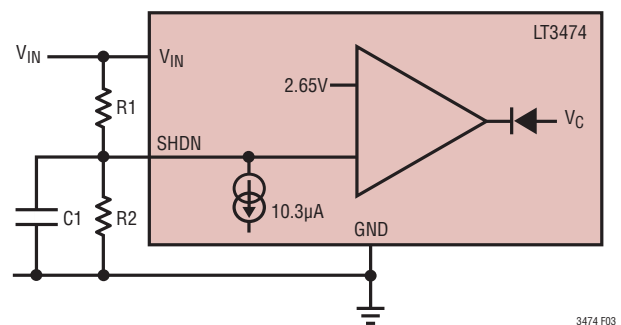

Figure 3. Undervoltage Lockout

APPLICATIONS INFORMATION

Setting the Switching Frequency

The LT3474 uses a constant frequency architecture that can be programmed over a 200kHz to 2MHz range with a single external timing resistor from the R_T pin to ground. The current that flows into the timing resistor is used to charge an internal oscillator capacitor. A graph for selecting the value of R_T for a given operating frequency is shown in the Typical Performance Characteristics section. Table 1 shows suggested R_T selections for a variety of switching frequencies.

Table 1. Switching Frequencies

SWITCHING FREQUENCY (MHz)	R_T (k Ω)
2	10
1.5	18.7
1	33.2
0.7	52.3
0.5	80.6
0.3	147
0.2	232

Operating Frequency Selection

The choice of operating frequency is determined by several factors. There is a tradeoff between efficiency and component size. Higher switching frequency allows the use of smaller inductors at the cost of increased switching losses and decreased efficiency.

Another consideration is the maximum duty cycle. In certain applications, the converter needs to operate at a high duty cycle in order to work at the lowest input voltage possible. The LT3474 has a fixed oscillator off-time and a variable on-time. As a result, the maximum duty cycle increases as the switching frequency is decreased.

Input Voltage Range

The minimum operating voltage is determined either by the LT3474's undervoltage lockout of 4V, or by its maximum duty cycle. The duty cycle is the fraction of time that the internal switch is on and is determined by the input and output voltages:

$$DC = \frac{(V_{OUT} + V_F)}{(V_{IN} - V_{SW} + V_F)}$$

where V_F is the forward voltage drop of the catch diode (~0.4V) and V_{SW} is the voltage drop of the internal switch (~0.4V at maximum load). This leads to a minimum input voltage of:

$$V_{IN(MIN)} = \frac{V_{OUT} + V_F}{DC_{MAX}} - V_F + V_{SW}$$

with $DC_{MAX} = 1 - t_{OFF(MIN)} \cdot f$

where $t_{OFF(MIN)}$ is equal to 200ns and f is the switching frequency.

Example: $f = 500\text{kHz}$, $V_{OUT} = 4\text{V}$

$$DC_{MAX} = 1 - 200\text{ns} \cdot 500\text{kHz} = 0.90$$

$$V_{IN(MIN)} = \frac{4\text{V} + 0.4\text{V}}{0.9} - 0.4\text{V} + 0.4\text{V} = 4.9\text{V}$$

The maximum operating voltage is determined by the absolute maximum ratings of the V_{IN} and BOOST pins, and by the minimum duty cycle.

$$V_{IN(MAX)} = \frac{V_{OUT} + V_F}{DC_{MIN}} - V_F + V_{SW}$$

with $DC_{MIN} = t_{ON(MIN)} \cdot f$

where $t_{ON(MIN)}$ is equal to 160ns and f is the switching frequency.

Example: $f = 500\text{kHz}$, $V_{OUT} = 2.5\text{V}$

$$DC_{MIN} = 160\text{ns} \cdot 500\text{kHz} = 0.08$$

$$V_{IN(MAX)} = \frac{2.5\text{V} + 0.4\text{V}}{0.08} - 0.4\text{V} + 0.4\text{V} = 36\text{V}$$

The minimum duty cycle depends on the switching frequency. Running at a lower switching frequency might allow a higher maximum operating voltage. Note that this is a restriction on the operating input voltage; the circuit will tolerate transient inputs up to the Absolute Maximum Rating.

APPLICATIONS INFORMATION

Inductor Selection and Maximum Output Current

A good first choice for the inductor value is

$$L = (V_{OUT} + V_F) \cdot \frac{900\text{kHz}}{f}$$

where V_F is the voltage drop of the catch diode ($\sim 0.4\text{V}$), f is the switching frequency and L is in μH . With this value the maximum load current will be 1.1A, independent of input voltage. The inductor's RMS current rating must be greater than the maximum load current and its saturation current should be at least 30% higher. For highest efficiency, the series resistance (DCR) should be less than 0.2Ω . Table 2 lists several vendors and types that are suitable. For robust operation at full load and high input voltages ($V_{IN} > 30\text{V}$), use an inductor with a saturation current higher than 2.5A.

Table 2. Inductors

PART NUMBER	VALUE (μH)	I_{RMS} (A)	DCR (Ω)	HEIGHT (mm)
Sumida				
CR43-3R3	3.3	1.44	0.086	3.5
CR43-4R7	4.7	1.15	0.109	3.5
CDRH4D16-3R3	3.3	1.1	0.063	1.8
CDRH4D28-3R3	3.3	1.57	0.049	3
CDRH4D28-4R7	4.7	1.32	0.072	3
CDRH5D28-100	10	1.3	0.048	3
CDRH5D28-150	15	1.1	0.076	3
CDRH73-100	10	1.68	0.072	3.4
CDRH73-150	15	1.33	0.13	3.4
Coilcraft				
DO1606T-332	3.3	1.3	0.1	2
DO1606T-472	4.7	1.1	0.12	2
DO1608C-332	3.3	2	0.08	2.9
DO1608C-472	4.7	1.5	0.09	2.9
MOS6020-332	3.3	1.8	0.046	2
MOS6020-472	10	1.5	0.05	2

The optimum inductor for a given application may differ from the one indicated by this simple design guide. A larger value inductor provides a higher maximum load current, and reduces the output voltage ripple. If your load is lower than the maximum load current, then you can relax the value of the inductor and operate with higher ripple current. This allows you to use a physically smaller inductor, or one with a lower DCR resulting in higher efficiency. Be aware that if the inductance differs from the simple rule above, then the maximum load current will depend on input voltage. In addition, low inductance may result in discontinuous mode operation, which further reduces maximum load current. For details of maximum output current and discontinuous mode operation, see Linear Technology's Application Note 44. Finally, for duty cycles greater than 50% ($V_{OUT}/V_{IN} > 0.5$), a minimum inductance is required to avoid sub-harmonic oscillations. See Application Note 19.

The current in the inductor is a triangle wave with an average value equal to the load current. The peak switch current is equal to the output current plus half the peak-to-peak inductor ripple current. The LT3474 limits its switch current in order to protect itself and the system from overload faults. Therefore, the maximum output current that the LT3474 will deliver depends on the switch current limit, the inductor value, and the input and output voltages.

When the switch is off, the potential across the inductor is the output voltage plus the catch diode drop. This gives the peak-to-peak ripple current in the inductor

$$\Delta I_L = \frac{(1-DC)(V_{OUT} + V_F)}{(L \cdot f)}$$

where f is the switching frequency of the LT3474 and L is the value of the inductor. The peak inductor and switch current is

$$I_{SW(PK)} = I_{L(PK)} = I_{OUT} + \frac{\Delta I_L}{2}$$

APPLICATIONS INFORMATION

To maintain output regulation, this peak current must be less than the LT3474's switch current limit I_{LIM} . For SW1, I_{LIM} is at least 1.6A (1.5A at 125°C) at low duty cycles and decreases linearly to 1.15A (1.08A at 125°C) at DC = 0.8. The maximum output current is a function of the chosen inductor value:

$$I_{OUT(MAX)} = I_{LIM} - \frac{\Delta I_L}{2}$$

$$= 1.6A \cdot (1 - 0.35 \cdot DC) - \frac{\Delta I_L}{2}$$

Choosing an inductor value so that the ripple current is small will allow a maximum output current near the switch current limit.

One approach to choosing the inductor is to start with the simple rule given above, look at the available inductors, and choose one to meet cost or space goals. Then use these equations to check that the LT3474 will be able to deliver the required output current. Note again that these equations assume that the inductor current is continuous. Discontinuous operation occurs when I_{OUT} is less than $\Delta I_L/2$.

Input Capacitor Selection

Bypass the input of the LT3474 circuit with a 2.2μF or higher ceramic capacitor of X7R or X5R type. A lower value or a less expensive Y5V type will work if there is additional bypassing provided by bulk electrolytic capacitors or if the input source impedance is low. The following paragraphs describe the input capacitor considerations in more detail.

Step-down regulators draw current from the input supply in pulses with very fast rise and fall times. The input capacitor is required to reduce the resulting voltage ripple

at the LT3474 input and to force this switching current into a tight local loop, minimizing EMI. The input capacitor must have low impedance at the switching frequency to do this effectively, and it must have an adequate ripple current rating. The RMS input is:

$$C_{INRMS} = I_{OUT} \cdot \frac{\sqrt{V_{OUT}(V_{IN} - V_{OUT})}}{V_{IN}} < \frac{I_{OUT}}{2}$$

and is largest when $V_{IN} = 2V_{OUT}$ (50% duty cycle). Considering that the maximum load current is 1A, RMS ripple current will always be less than 0.5A

The high switching frequency of the LT3474 reduces the energy storage requirements of the input capacitor, so that the capacitance required is less than 10μF. The combination of small size and low impedance (low equivalent series resistance or ESR) of ceramic capacitors makes them the preferred choice. The low ESR results in very low voltage ripple. Ceramic capacitors can handle larger magnitudes of ripple current than other capacitor types of the same value. Use X5R and X7R types.

An alternative to a high value ceramic capacitor is a lower value ceramic along with a larger electrolytic capacitor. The electrolytic capacitor likely needs to be greater than 10μF in order to meet the ESR and ripple current requirements. The input capacitor is likely to see high surge currents when the input source is applied. Tantalum capacitors can fail due to an over-surge of current. Only use tantalum capacitors with the appropriate surge current rating. The manufacturer may also recommend operation below the rated voltage of the capacitor.

APPLICATIONS INFORMATION

A final caution is in order regarding the use of ceramic capacitors at the input. A ceramic input capacitor can combine with stray inductance to form a resonant tank circuit. If power is applied quickly (for example by plugging the circuit into a live power source), this tank can ring, doubling the input voltage and damaging the LT3474. The solution is to either clamp the input voltage or dampen the tank circuit by adding a lossy capacitor in parallel with the ceramic capacitor. For details, see Application Note 88.

Output Capacitor Selection

For most LEDs, a 2.2µF 6.3V ceramic capacitor (X5R or X7R) at the output results in very low output voltage ripple and good transient response. Other types and values will also work; the following discusses tradeoffs in output ripple and transient performance.

The output capacitor filters the inductor current to generate an output with low voltage ripple. It also stores energy in order to satisfy transient loads and stabilizes the LT3474's control loop. Because the LT3474 operates at a high frequency, minimal output capacitance is necessary. In addition, the control loop operates well with or without the presence of output capacitor series resistance (ESR). Ceramic capacitors, which achieve very low output ripple and small circuit size, are therefore an option.

You can estimate output ripple with the following equation:

$$V_{\text{RIPPLE}} = \frac{\Delta I_L}{(8 \cdot f \cdot C_{\text{OUT}})} \quad \text{for ceramic capacitors}$$

where ΔI_L is the peak-to-peak ripple current in the inductor. The RMS content of this ripple is very low so the RMS current rating of the output capacitor is usually not of concern. It can be estimated with the formula:

$$I_{\text{C(RMS)}} = \frac{\Delta I_L}{\sqrt{12}}$$

The low ESR and small size of ceramic capacitors make them the preferred type for LT3474 applications. Not all ceramic capacitors are the same, however. Many of the higher value capacitors use poor dielectrics with high temperature and voltage coefficients. In particular, Y5V and Z5U types lose a large fraction of their capacitance with applied voltage and at temperature extremes.

Because loop stability and transient response depend on the value of C_{OUT} , this loss may be unacceptable. Use X7R and X5R types. Table 3 lists several capacitor vendors.

Table 3. Low-ESR Surface Mount Capacitors

VENDOR	TYPE	SERIES
Taiyo-Yuden	Ceramic	X5R, X7R
AVX	Ceramic	X5R, X7R
TDK	Ceramic	X5R, X7R

APPLICATIONS INFORMATION

Diode Selection

The catch diode (D1 from Figure 1) conducts current only during switch off time. Average forward current in normal operation can be calculated from:

$$I_{D(AVG)} = \frac{I_{OUT}(V_{IN} - V_{OUT})}{V_{IN}}$$

The only reason to consider a diode with a larger current rating than necessary for nominal operation is for the worst-case condition of shorted output. The diode current will then increase to one half the typical peak switch current.

Peak reverse voltage is equal to the regulator input voltage. Use a diode with a reverse voltage rating greater than the input voltage.

If using the PWM mode of the LT3474, select a diode with low reverse leakage.

Table 4 lists several Schottky diodes and their manufacturers.

Table 4. Schottky Diodes

PART NUMBER	V _R (V)	I _{Ave} (A)	V _F at 0.5A (mV)	V _F at 1A (mV)
On Semiconductor				
MBR0520L	20	0.5	385	
MBR0540	40	0.5	510	620
MBRM120E	20	1		530
MBRM140	40	1		550
Diodes Inc.				
B0530W	30	0.5	430	
B120	20	1		500
B130	30	1		500
B140 HB	40	1		530
International Rectifier				
10BQ030	30	1		420

APPLICATIONS INFORMATION

BOOST and BIAS Pin Considerations

The capacitor and internal diode tied to the BOOST pin generate a voltage that is higher than the input voltage. In most cases, a 0.22μF capacitor will work well. Figure 4 shows three ways to arrange the boost circuit. The BOOST pin must be more than 2.5V above the SW pin for full efficiency. For outputs of 2.8V or higher, the standard circuit (Figure 4a) is best. For lower output voltages, the BIAS pin

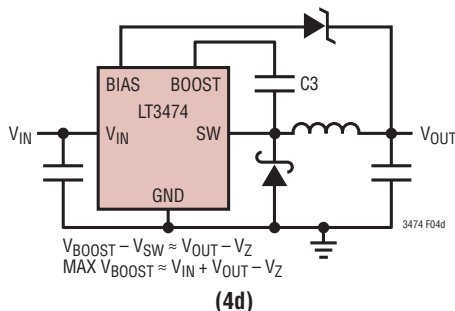
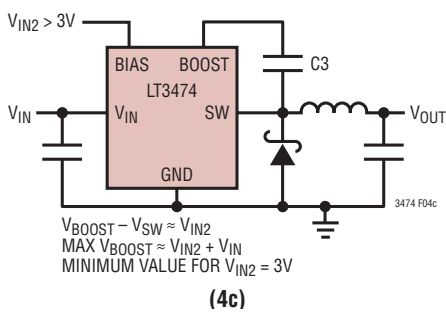
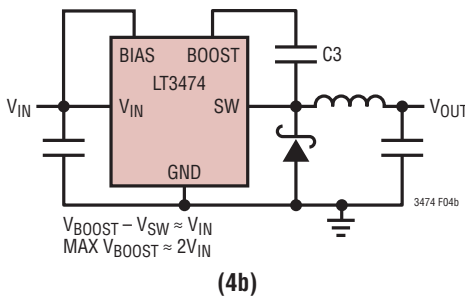
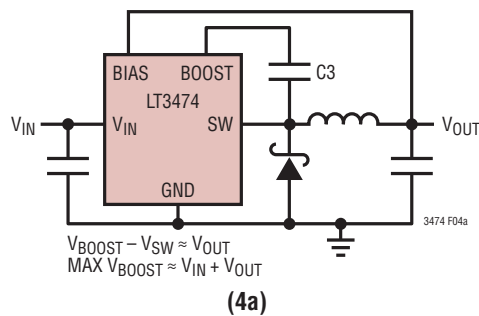

Figure 4. Generating the Boost Voltage

can be tied to the input (Figure 4b). The circuit in Figure 4a is more efficient because the BOOST pin current comes from a lower voltage source. The BIAS pin can be tied to another source that is at least 3V (Figure 4c). For example, if a 3.3V source is on whenever the LED is on, the BIAS pin can be connected to the 3.3V output. For LT3474-1 applications with higher output voltages, an additional Zener diode may be necessary (Figure 4d) to maintain the BOOST pin voltage below the absolute maximum. In any case, be sure that the maximum voltage at the BOOST pin is both less than 51V and the voltage difference between the BOOST and SW pins is less than 25V.

Programming LED Current

The LED current can be set by adjusting the voltage on the V_{ADJ} pin. For a 1A LED current, either tie V_{ADJ} to REF or to a 1.25V source. For lower output currents, program the V_{ADJ} using the following formula:

$$I_{LED} = \frac{1A \cdot V_{ADJ}}{1.25V}$$

Voltages less than 1.25V can be generated with a voltage divider from the REF pin, as shown in Figure 5.

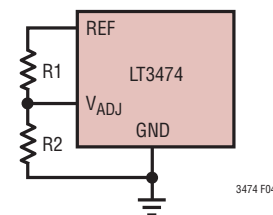

Figure 5. Setting V_{ADJ} with a Resistor Divider

In order to have accurate LED current, precision resistors are preferred (1% or better is recommended). Note that the V_{ADJ} pin sources a small amount of bias current, so use the following formula to choose resistors:

$$R2 = \frac{V_{ADJ}}{\frac{1.25V - V_{ADJ}}{R1} + 50nA}$$

APPLICATIONS INFORMATION

To minimize the error from variations in V_{ADJ} pin current, use resistors with a parallel resistance of less than 4k. Use resistors with a series resistance of 5.11k or greater so as not to exceed the 250 μ A current limit on the REF pin.

Dimming Control

There are several different types of dimming control circuits. One dimming control circuit (Figure 6) changes the voltage on the V_{ADJ} pin by tying a low on-resistance FET to the resistor divider string. This allows the selection of two different LED currents. For reliable operation, program an LED current of no less than 35mA. The maximum current dimming ratio (I_{RATIO}) can be calculated from the maximum LED current (I_{MAX}) and the minimum LED current (I_{MIN}) as follows:

$$\frac{I_{MAX}}{I_{MIN}} = I_{RATIO}$$

Another dimming control circuit (Figure 7) uses the PWM pin and an external NFET tied to the cathode of the LED. When the PWM signal goes low, the NFET turns off, turning off the LED and leaving the output capacitor charged. The PWM pin is pulled low as well, which disconnects the V_C pin, storing the voltage in the capacitor tied there. Use

the C-RC string (tied to the V_C pin) shown in Figure 7 for proper operation during start-up. When the PWM pin goes high again, the LED current returns rapidly to its previous on state since the compensation and output capacitors are at the correct voltage. This fast settling time allows The LT3474 to maintain diode current regulation with PWM pulse widths as short as 40 μ s. If the NFET is omitted and the cathode of the LED is instead tied to GND, use PWM pulse widths of 1ms or greater. The maximum PWM dimming ratio (PWM_{RATIO}) can be calculated from the maximum PWM period (t_{MAX}) and minimum PWM pulse width (t_{MIN}) as follows:

$$\frac{t_{MAX}}{t_{MIN}} = PWM_{RATIO}$$

Total dimming ratio (DIM_{RATIO}) is the product of the PWM dimming ratio and the current dimming ratio.

Example: $I_{MAX} = 1A$, $I_{MIN} = 0.1A$, $t_{MAX} = 12ms$, $t_{MIN} = 40\mu s$

$$I_{RATIO} = \frac{1A}{0.1A} = 10:1$$

$$PWM_{RATIO} = \frac{12ms}{40\mu s} = 300:1$$

$$DIM_{RATIO} = 10 \cdot 300 = 3000:1$$

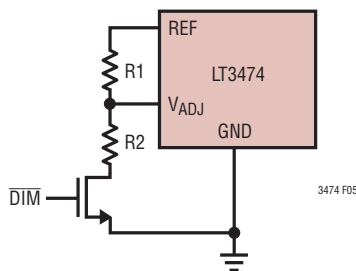

Figure 6. Dimming with an NFET and Resistor Divider

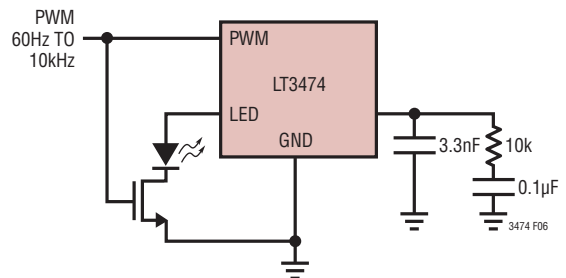

Figure 7. Dimming Using PWM Signal

APPLICATIONS INFORMATION

LED Voltage Range

The LT3474 can drive LED voltages from 2.4V to 12V. The LT3474-1 can drive LED voltages from 2.4V to 30V. Be careful not to exceed the ABSMAX rating of the OUT, LED, or BOOST pins of the LT3474-1 since the internal output clamp is disabled. See the Typical Application section for an example of adding an external output clamp. If the LED voltage can drift below 2.4V due to temperature or component variation, add extra series resistance to bring the overall voltage above 2.4V.

Layout Hints

As with all switching regulators, careful attention must be paid to the PCB layout and component placement. To maximize efficiency, switch rise and fall times are made

as short as possible. To prevent electromagnetic interference (EMI) problems, proper layout of the high frequency switching path is essential. The voltage signal of the SW and BOOST pins have sharp rise and fall edges. Minimize the area of all traces connected to the BOOST and SW pins and always use a ground plane under the switching regulator to minimize interplane coupling. In addition, the ground connection for frequency setting resistor R_T (refer to Figure 1) should be tied directly to the GND pin and not shared with any other component, ensuring a clean, noise-free connection.

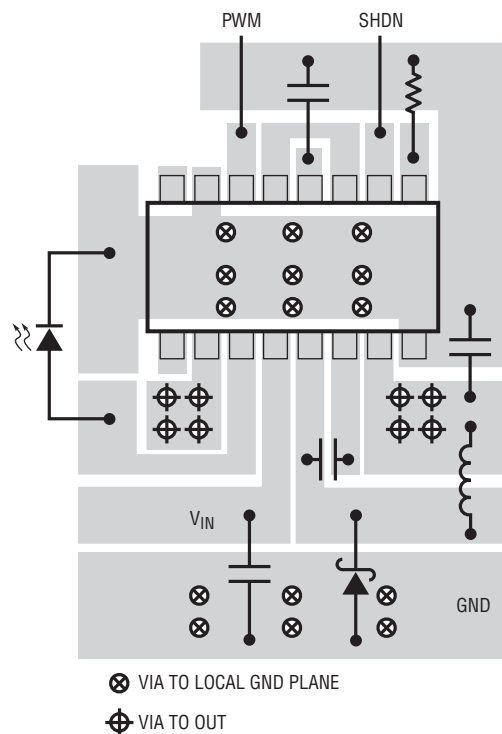
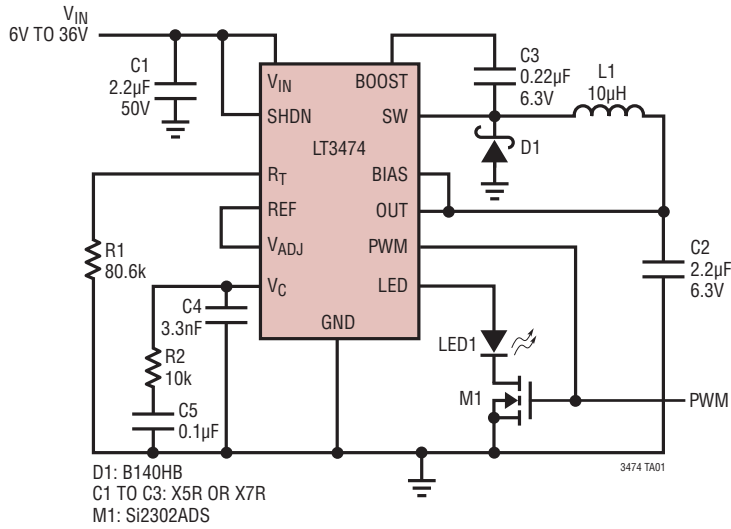

Figure 8. Recommended Component Placement

TYPICAL APPLICATIONS

Step-Down 1A LED Driver with PWM Dimming



LED Current in PWM Mode

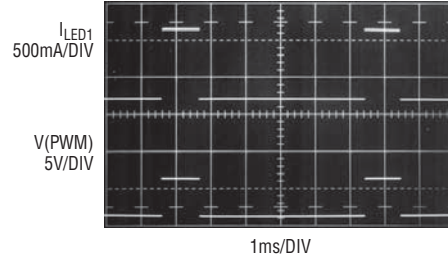

Step-Down 1A LED Driver with Two Series Connected LED Output

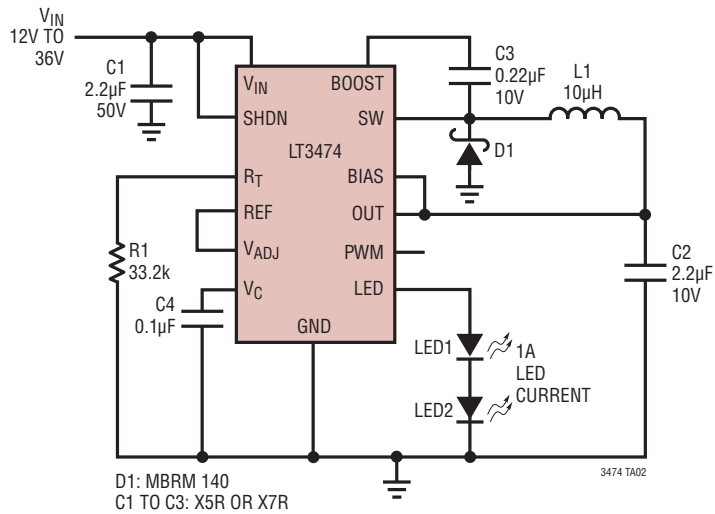

Efficiency, Two LED Output

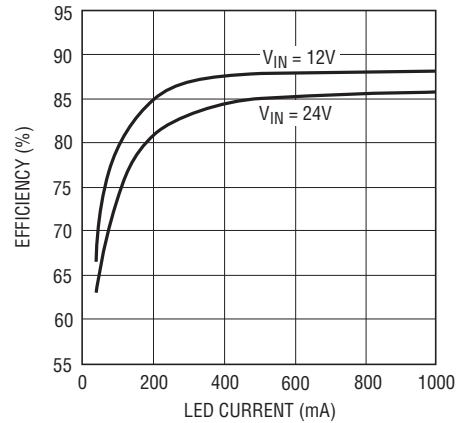

PACKAGE DESCRIPTION

FE Package
16-Lead Plastic TSSOP (4.4mm)
 (Reference LTC DWG # 05-08-1663)
Exposed Pad Variation BA

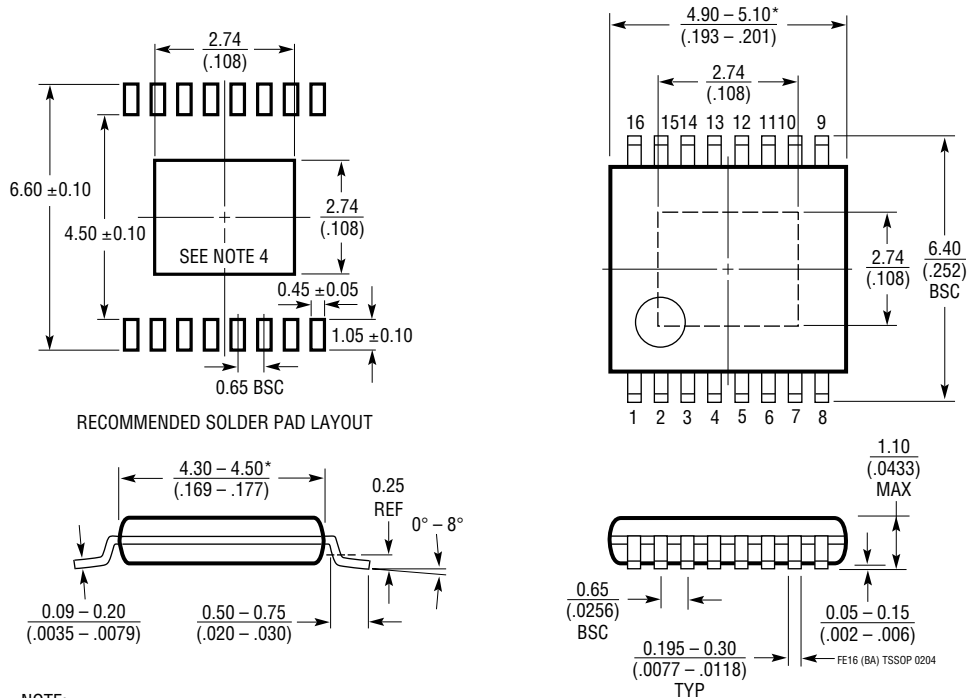

- NOTE:
1. CONTROLLING DIMENSION: MILLIMETERS
 2. DIMENSIONS ARE IN $\frac{\text{MILLIMETERS}}{\text{(INCHES)}}$
 3. DRAWING NOT TO SCALE
 4. RECOMMENDED MINIMUM PCB METAL SIZE FOR EXPOSED PAD ATTACHMENT
- *DIMENSIONS DO NOT INCLUDE MOLD FLASH. MOLD FLASH SHALL NOT EXCEED 0.150mm (.006") PER SIDE

TYPICAL APPLICATION

Step-Down 1A LED Driver with Four Series Connected LED Output

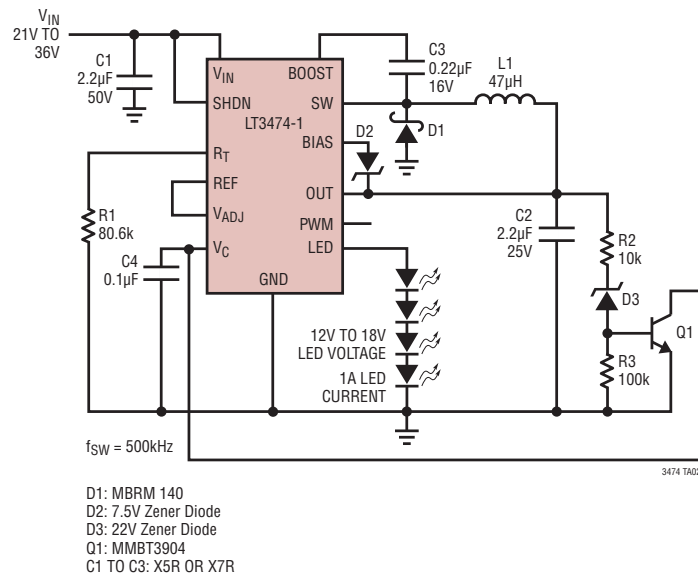

RELATED PARTS

PART NUMBER	DESCRIPTION	COMMENTS
LT1618	Constant Current, 1.4MHz, 1.5A Boost Converter	V_{IN} : 1.6V to 18V, $V_{OUT(MAX)}$ = 36V, I_Q = 1.8mA, I_{SD} = <1µA, MS10 Package
LT1766	60V, 1.2A (I_{OUT}), 200kHz, High Efficiency Step-Down DC/DC Converter	V_{IN} : 5.5V to 60V, $V_{OUT(MAX)}$ = 1.20V, I_Q = 2.5mA, I_{SD} = 25µA, TSSOP16/E Packages
LT1956	60V, 1.2A (I_{OUT}), 500kHz, High Efficiency Step-Down DC/DC Converter	V_{IN} : 5.5V to 60V, $V_{OUT(MAX)}$ = 1.20V, I_Q = 2.5mA, I_{SD} = 25µA, TSSOP16/E Packages
LT1961	1.5A (I_{SW}), 1.25MHz, High Efficiency Step-Up DC/DC Converter	V_{IN} : 3V to 25V, $V_{OUT(MAX)}$ = 35V, I_Q = 0.9mA, I_{SD} = 6µA, MS8E Package
LT1976/LT1977	60V, 1.2A (I_{OUT}), 200kHz/500kHz, High Efficiency Step-Down DC/DC Converters with BurstMode® Operation	V_{IN} : 3.3V to 60V, $V_{OUT(MAX)}$ = 1.20V, I_Q = 100µA, I_{SD} = <1µA, TSSOP16E Package
LT3430/LT3431	60V, 2.5A (I_{OUT}), 200kHz, High Efficiency Step-Down DC/DC Converters	V_{IN} : 5.5V to 60V, $V_{OUT(MAX)}$ = 1.20V, I_Q = 2.5µA, I_{SD} = <25µA, TSSOP16/E Packages
LT3433	60V, 400mA (I_{OUT}), 200kHz, High Efficiency Step-Up/Step-Down DC/DC Converters with Burst Mode Operation	V_{IN} : 4V to 60V, V_{OUT} : 3.3V to 20V, I_Q = 100µA, I_{SD} = <1µA, TSSOP16E Package
LT3434/LT3435	60V, 2.5A (I_{OUT}), 200kHz/500kHz, High Efficiency Step-Down DC/DC Converters with Burst Mode Operation	V_{IN} : 3.3V to 60V, $V_{OUT(MAX)}$ = 1.20V, I_Q = 100µA, I_{SD} = <1µA, TSSOP16E Package
LTC3453	1MHz, 800mA Synchronous Buck-Boost High Power LED Driver	V_{IN} : 2.7V to 5.5V, $V_{OUT(MAX)}$ = 5.5V, I_Q = 2.5mA, I_{SD} = <6µA, QFN Package
LT3467/LT3467A	1.1A (I_{SW}), 1.3MHz/2.1MHz, High Efficiency Step-Up DC/DC Converters with Integrated Soft-Start	V_{IN} : 2.4V to 16V, $V_{OUT(MAX)}$ = 40V, I_Q = 1.2mA, I_{SD} = <1µA, ThinSOT™ Package
LT3477	3A, 42V, 3MHz Step-Up Regulator with Dual Rail to Rail Current Sense	V_{IN} : 2.5V to 2.5V, $V_{OUT(MAX)}$ = 40V, I_Q = 5mA, I_{SD} = <1µA, QFN, TSSOP16E Packages
LT3479	3A, Full Featured DC/DC Converter with Soft-Start and Inrush Current Protection	V_{IN} : 2.5V to 24V, $V_{OUT(MAX)}$ = 40V, I_Q = 6.5mA, I_{SD} = <1µA, DFN and TSSOP Packages

Burst Mode is a registered trademark of Linear Technology Corporation.
ThinSOT is a trademark of Linear Technology Corporation.